

STIEBEL ELTRON

CES Plus Series: 120 kW, 144 kW | Standard Indoor Enclosure, NEMA 4/4X Engineering Specification Sheet

Specifications

Model	CES Plus 120 kW, CES Plus 144 kW
Phase	3-phase
Inlet/outlet pipe connection	1¼" female NPT
Heat exchanger material	316L stainless steel
Enclosure rating	Standard indoor shown, NEMA 4/4X available
Operating pressure range	4-145 psi (0.28-10 bar)
Maximum temperature output	90 °F (32 °C)
Temperature adjustment range	60-90 °F (16-32 °C)
Temperature adjustment increment	1 °F (1 °C)
Number of heating elements	24
Minimum activation flow	2.7 gpm (10.2 l/m)
Maximum flow at 60 psi	40 gpm (151.4 l/m)



Model	Part Number	Voltage	Phase	kW	Amps	3P Breaker Size (A)	Temperature Rise °F				
							5 gpm	10 gpm	15 gpm	20 gpm	40 gpm
CES Plus 120 kW	CESPLUS-120-480	480	3-phase delta	120.00	144.34	175	>100	82	55	41	21
CES Plus 144 kW	CESPLUS-144-480	480	3-phase delta	144.00	173.21	200	>100	98	66	49	25
	CESPLUS-144-575	575	3-phase delta	144.00	144.59	175	>100	98	66	49	25



Certified to ANSI/UL Std. 499
Conforms to CAN/CSA
Std. C22.2 No.88



6 years against leakage /
2 years against defects in
workmanship & materials

rev. 6.2026 Due to our continuous process of engineering and technological advancement, specifications may change without notice.

Dimensions

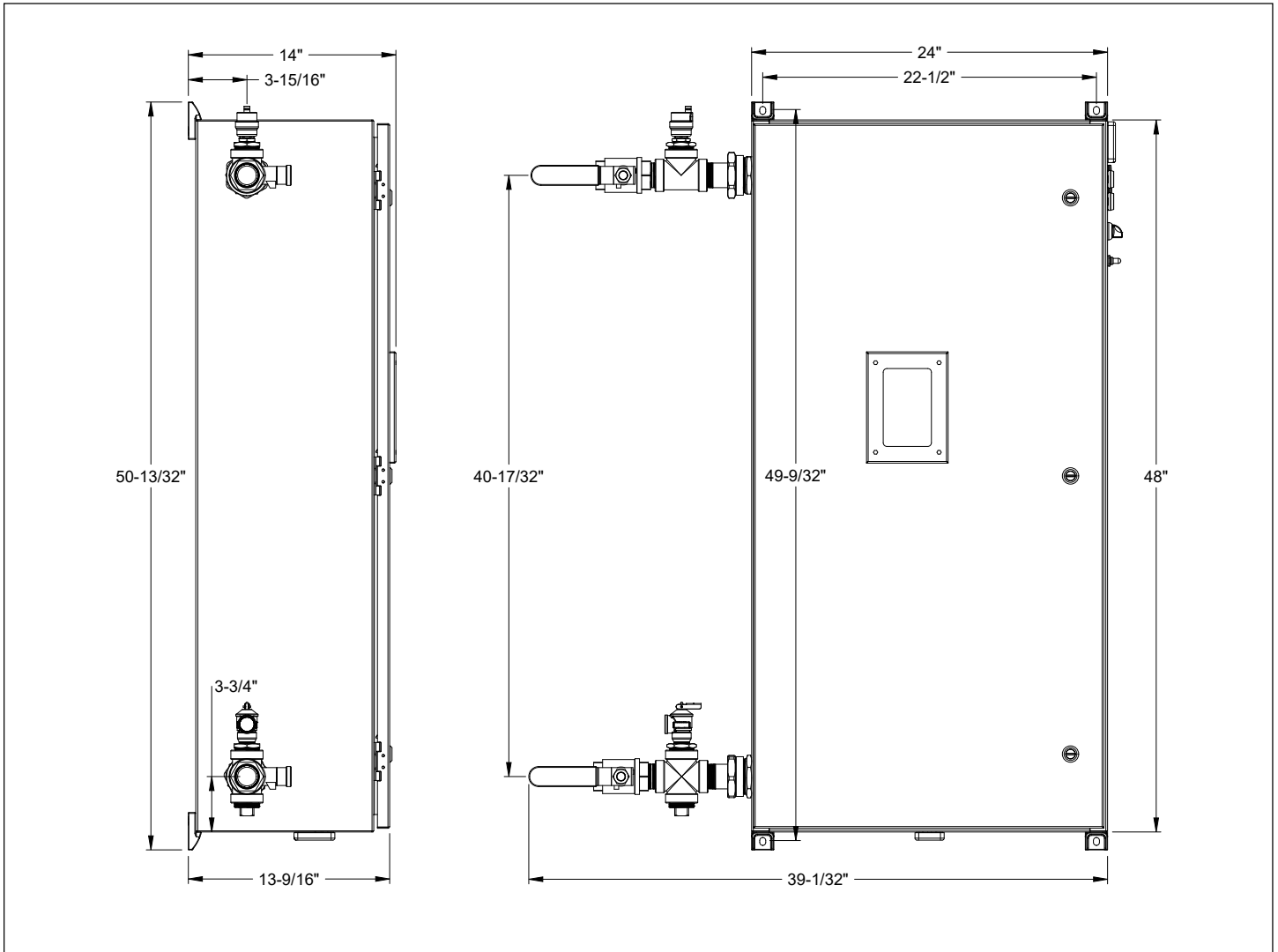

rev. 6.2026 Due to our continuous process of engineering and technological advancement, specifications may change without notice.

Dimensions for optional legs for NEMA 4 & 4X enclosures

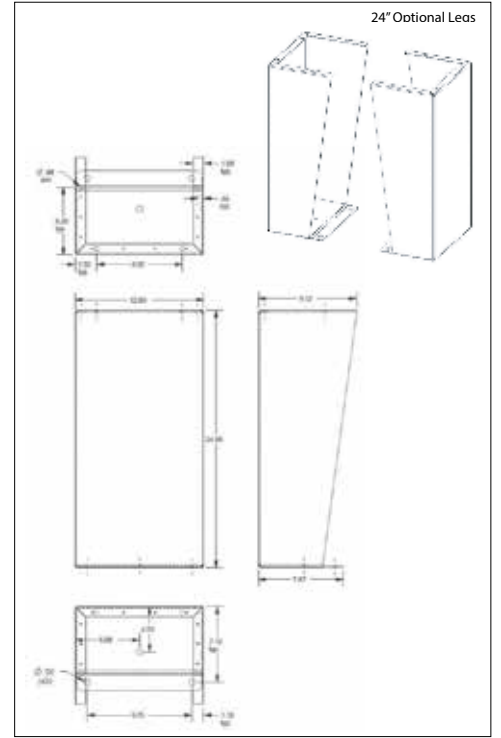
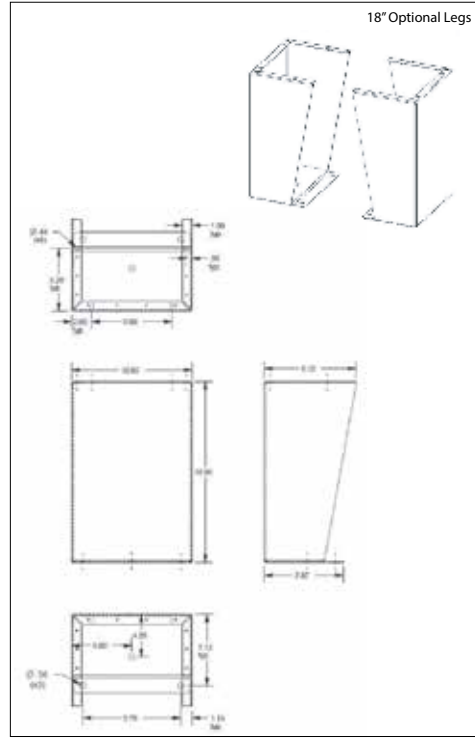
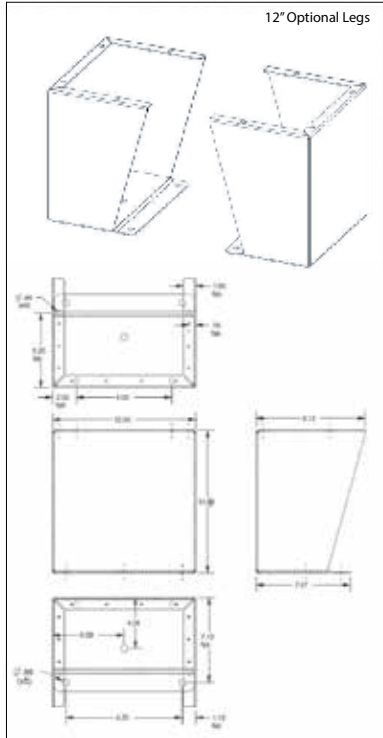

Temperature Rise vs. Flow Rate

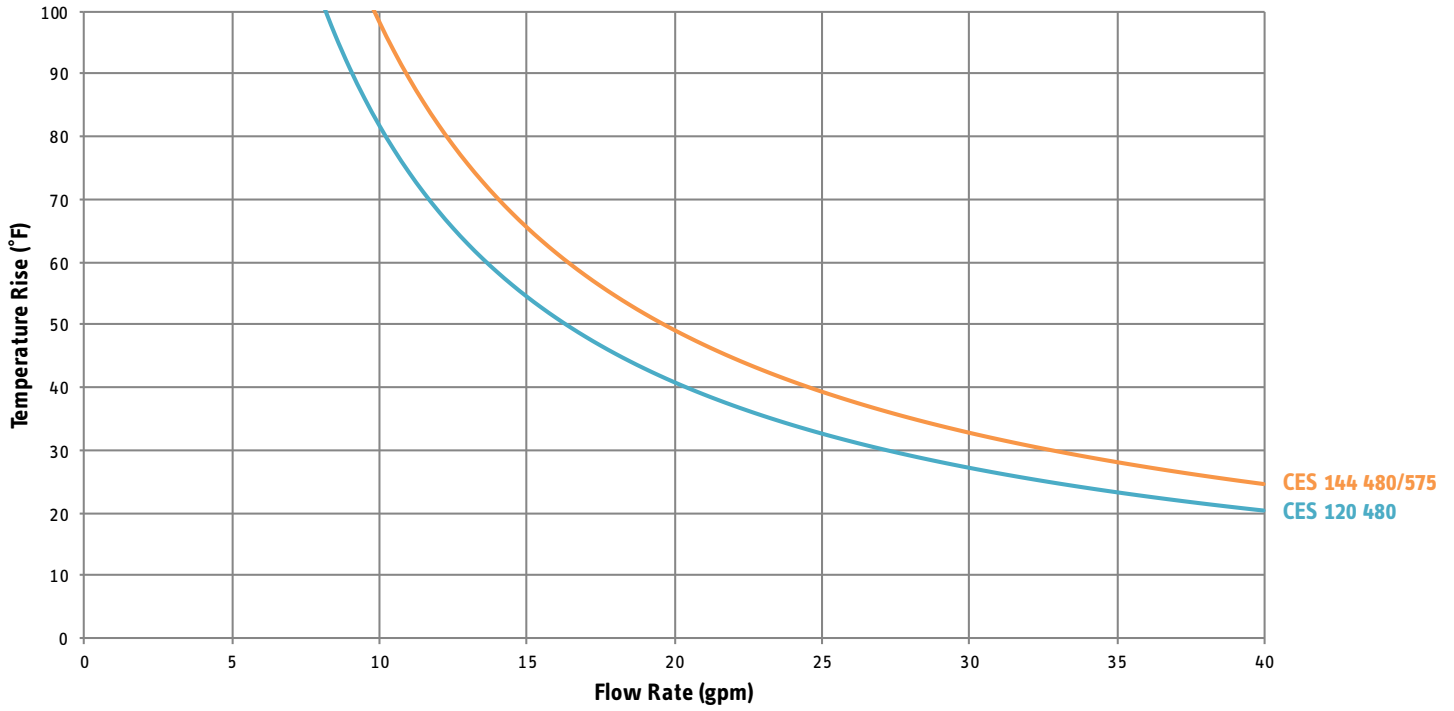

Pressure Drop vs. Flow Rate

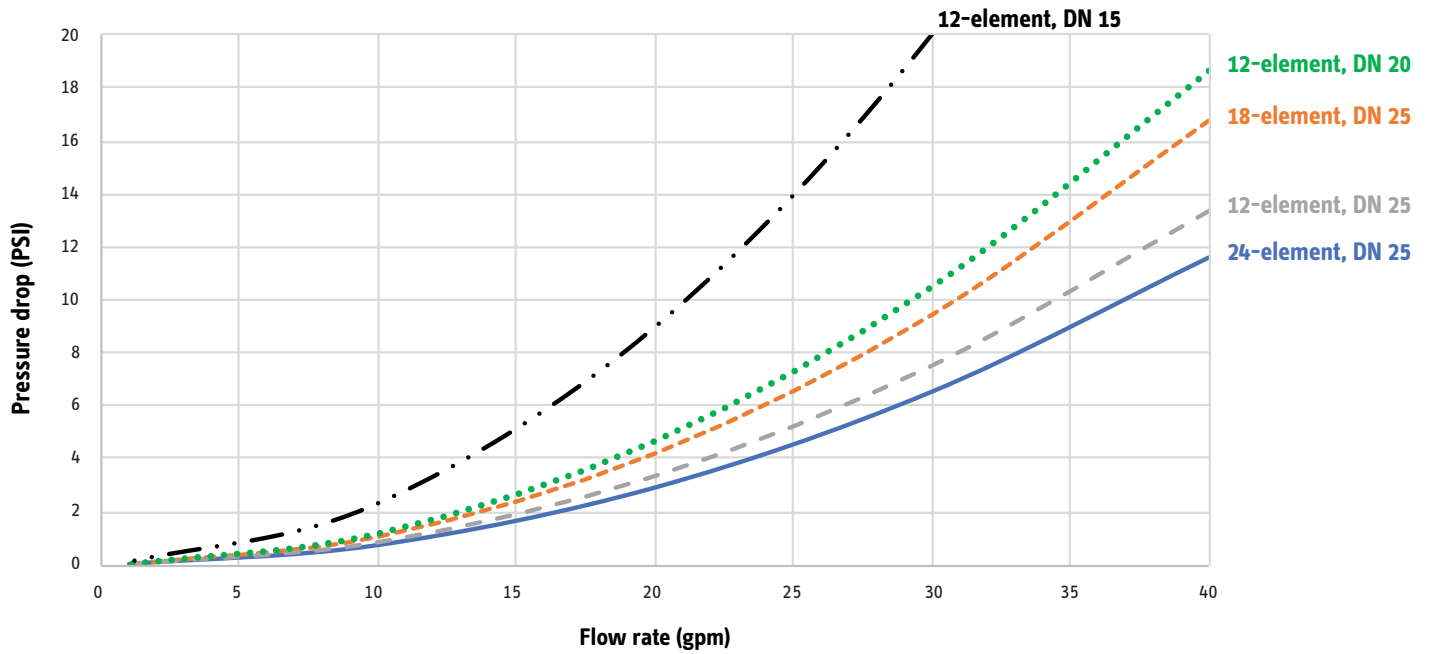

rev. 6.2026 Due to our continuous process of engineering and technological advancement, specifications may change without notice.