

# STIEBEL ELTRON

## CES Plus Series: 24 kW, 27 kW, 36 kW | Standard Indoor Enclosure Engineering Specification Sheet

### Specifications

<b>Model</b>	CES Plus 24 kW, CES Plus 27 kW, CES Plus 36 kW
<b>Phase</b>	3-phase
<b>Inlet/outlet pipe connection</b>	3/4" female NPT
<b>Heat exchanger material</b>	316L stainless steel
<b>Enclosure rating</b>	Standard indoor shown, NEMA 4/4X available
<b>Operating pressure range</b>	4-150 psi (0.27-10.3 bar)
<b>Maximum temperature output</b>	90 °F (32 °C)
<b>Temperature adjustment range</b>	60-90 °F (16-32 °C)
<b>Temperature adjustment increment</b>	1 °F (1 °C)
<b>Number of heating elements</b>	6
<b>Minimum activation flow</b>	1.2 gpm (4.5 l/m) for DN 15 flowmeter
<b>Maximum flow at 60 psi</b>	13.2 gpm (50 l/m)



Model	Part Number	Voltage	Phase	kW	Amps	3P Breaker Size (A)	Temperature Rise °F				
							1 gpm	2 gpm	3 gpm	5 gpm	10 gpm
CES Plus 24 kW	CESPLUS-024-208	208	3-phase delta	22.53	62.55	70	>100	77	51	31	15
	CESPLUS-024-240	240	3-phase delta	25.00	60.14	70	>100	85	57	34	17
	CESPLUS-024-480	480	3-phase delta	25.00	30.07	35	>100	85	57	34	17
	CESPLUS-024-575	575	3-phase delta	24.00	24.10	30	>100	82	55	33	16
CES Plus 27 kW	CESPLUS-027-208	208	3-phase delta	27.04	75.06	80	>100	92	62	37	18
	CESPLUS-027-240	240	3-phase delta	27.02	65.01	80	>100	92	62	37	18
	CESPLUS-027-480	480	3-phase delta	27.02	32.51	40	>100	92	62	37	18
CES Plus 36 kW	CESPLUS-036-208	208	3-phase delta	36.00	99.93	110	>100	>100	82	49	25
	CESPLUS-036-240	240	3-phase delta	36.00	86.60	100	>100	>100	82	49	25
	CESPLUS-036-480	480	3-phase delta	36.00	43.30	50	>100	>100	82	49	25
	CESPLUS-036-575	575	3-phase delta	36.00	36.15	40	>100	>100	82	49	25



Certified to ANSI/UL Std. 499  
Conforms to CAN/CSA  
Std. C22.2 No.88



6 years against leakage /  
2 years against defects in  
workmanship & materials

rev. 6.2026 Due to our continuous process of engineering and technological advancement, specifications may change without notice.

# Dimensions

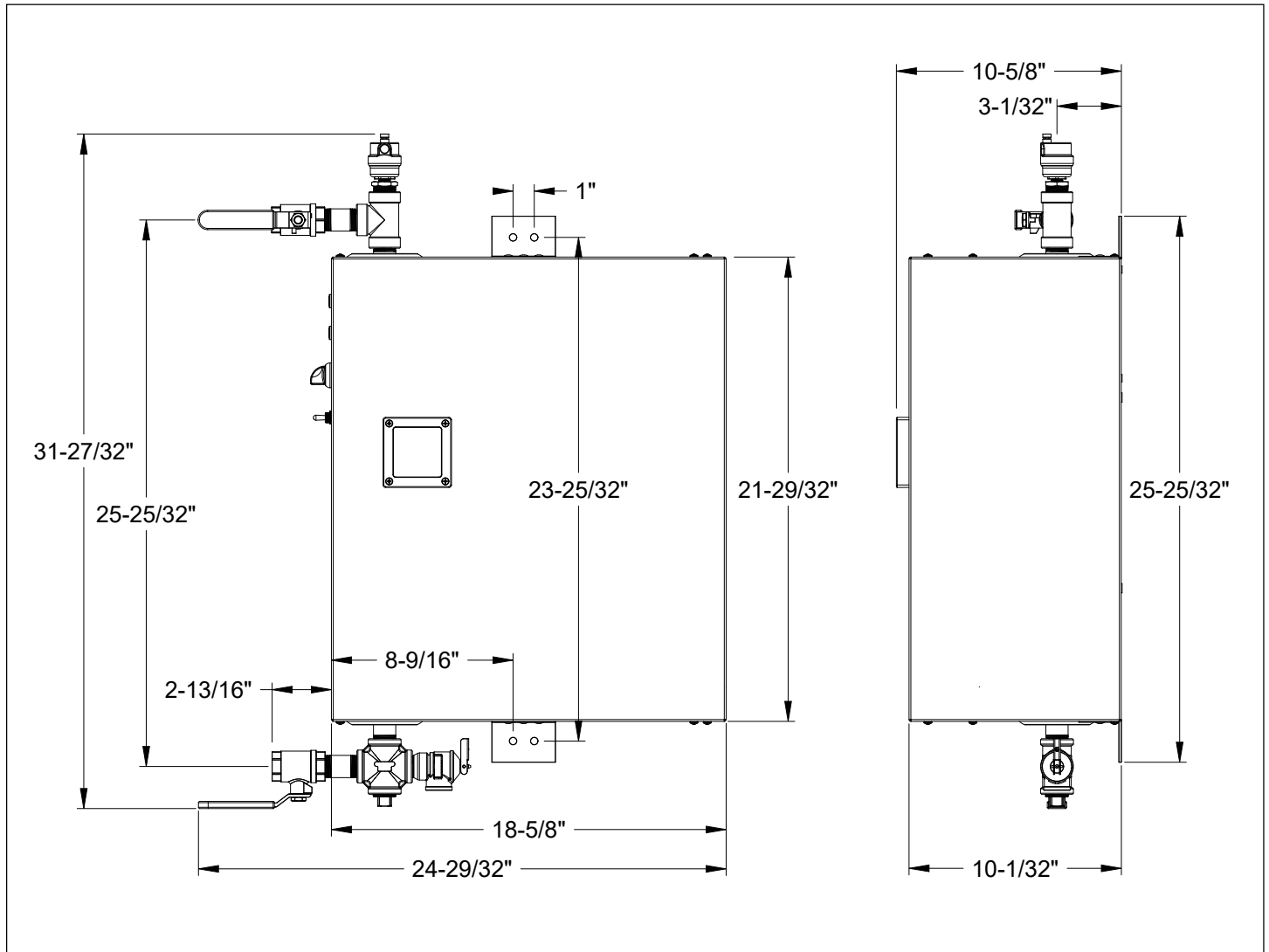

rev. 6.2026 Due to our continuous process of engineering and technological advancement, specifications may change without notice.

## Temperature Rise vs. Flow Rate

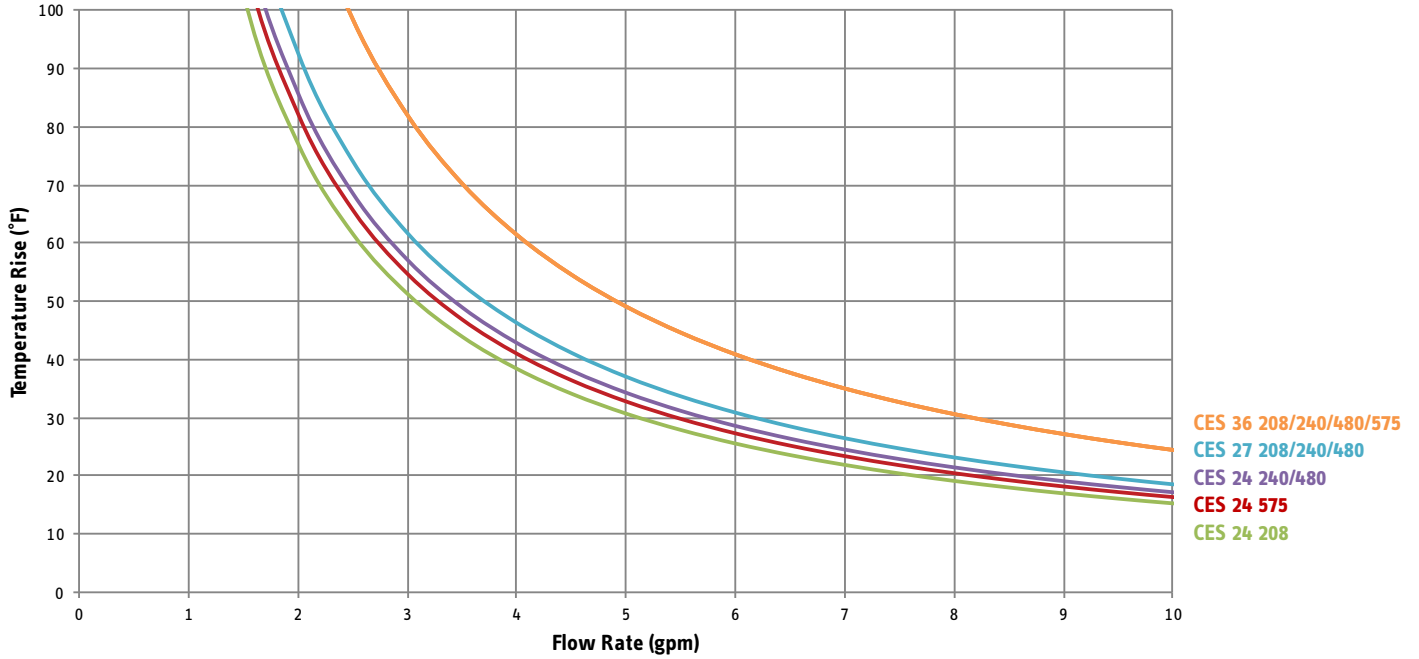

## Pressure Drop vs. Flow Rate

